



STRATUS

SYSTEM SOLUTIONS

**CREATING SPACE
WITHIN SPACE.**

ONE WALL SEVERAL SPACES. QUICK, EASY & SAFE.

Stratus System Solutions offer four distinct wall solutions which allow designers to craft adaptable, high-performing spaces that deliver lasting value for their clients.

The image presents four customizable wall systems, CUMULUS, NIMBUS, CIRRUS AND ALTO. Designed to adapt to changing space needs while maximizing productivity. With quick deployment, modular and precision-engineered construction, and the ability to scale to any room size with minimal effort.

The systems are highly flexible, with extensive finish options, quiet and smooth panel movement, and the ability to shift spaces from open and collaborative to private and focused. These solutions combine architectural customization, operational efficiency, and a sleek modern aesthetic.

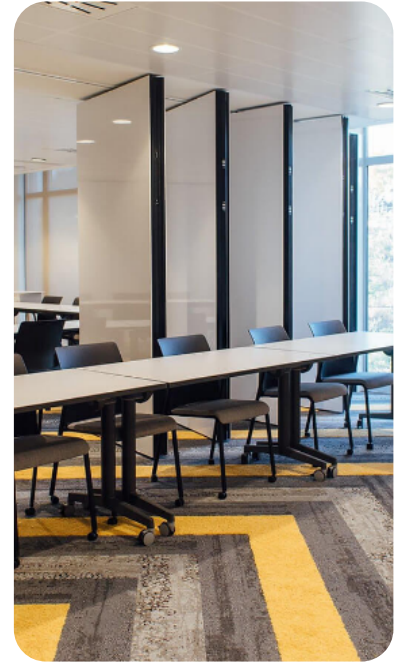



SOUND
INSULATION



FIRE RATING:
EI2.30



SMART



SEVERAL
FINISHES

CUMULUS

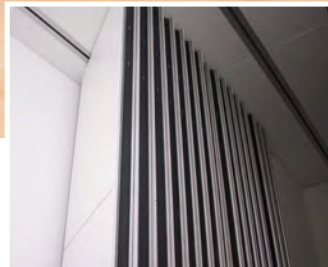
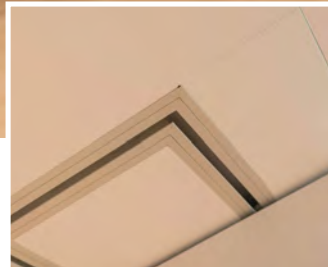
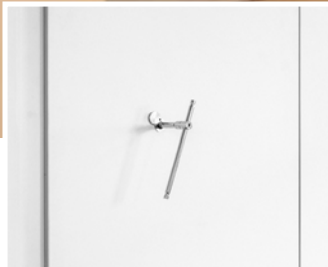

CUMULUS

ONE WALL. MULTIPLE POSSIBILITIES.

When flexibility meets performance, the result is a space that adapts without compromising privacy or acoustics. CUMULUS solid walls create seamless transitions between open collaboration and quiet concentration, with solid panels engineered for durability and high acoustic performance.

NIMBUS & CUMULUS

MIX

Fluid Design Meets Timeless Craft



Designed for environments that demand frequent reconfiguration and specialized division, the CUMULUS system offers single or double inset passdoors that are available in solid or double-glazed options. CUMULUS pairs seamlessly with NIMBUS for a fully integrated solution.



ADDED VALUE AT EVERY STEP

THE BENEFITS YOU'LL NOTICE

BENEFITS

- Creates flexible spaces that can shift between open and private environments.
- High acoustic insulation for improved focus and sound control.
- Supports multi-purpose rooms without permanent construction.
- Maintains design consistency with customizable finishes.





ADDED VALUE AT EVERY STEP

ENHANCED FEATURES. BETTER RESULTS.

ADDED FEATURES

- Sound Transmission Class (STC) rating of 42-57.
- Certified fire resistance (EI2.30).
- Integrated door options available.
- Telescopic panels for secure closures.
- Wide range of finish and coating options.
- Stackable up to 11 meters (36') in height.
- Segmented Curve
- Load bearing Uni-Directional or Multi-Directional track.
- Cumulus is available in Manual, Hybrid and Smart deployment options.

FINISHES COLLECTION

TIMELESS ELEGANCE, ENDLESS OPTIONS



MFC



Laminate



Fabric

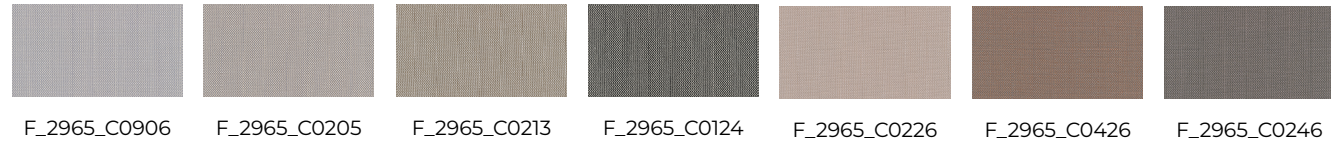

HPL



Writable

Custom RAL



Custom RAL

Note: Other profiles and custom finishes upon request.

STACKING SYSTEMS

CUMULUS supports configurations for parking panels when open, enabling flexible space division in architectural settings.



CENTRE STACKING SYSTEM

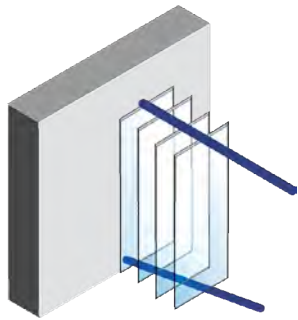

Centre Folding

MAIN STACKING SYSTEM

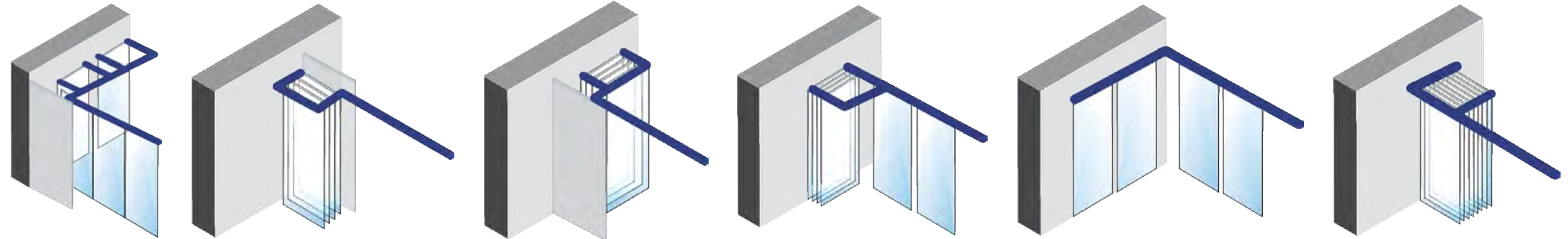

A

B

C

D

E

G



HEAD OFFICE
130 Nolan Court
Markham, ON L3R 2V7
Canada

T. 1-866-633-0233
E. hello@pc350.com
www.pc350.com

USA
T. 1-866-633-0233
E. hello@pc350.com

CARIBBEAN
T. 1-866-633-0233
E. hello@pc350.com



SOUND
INSULATION



FIRE RATING:
E12.30



SMART



SEVERAL
FINISHES



GLASS

NIMBUS

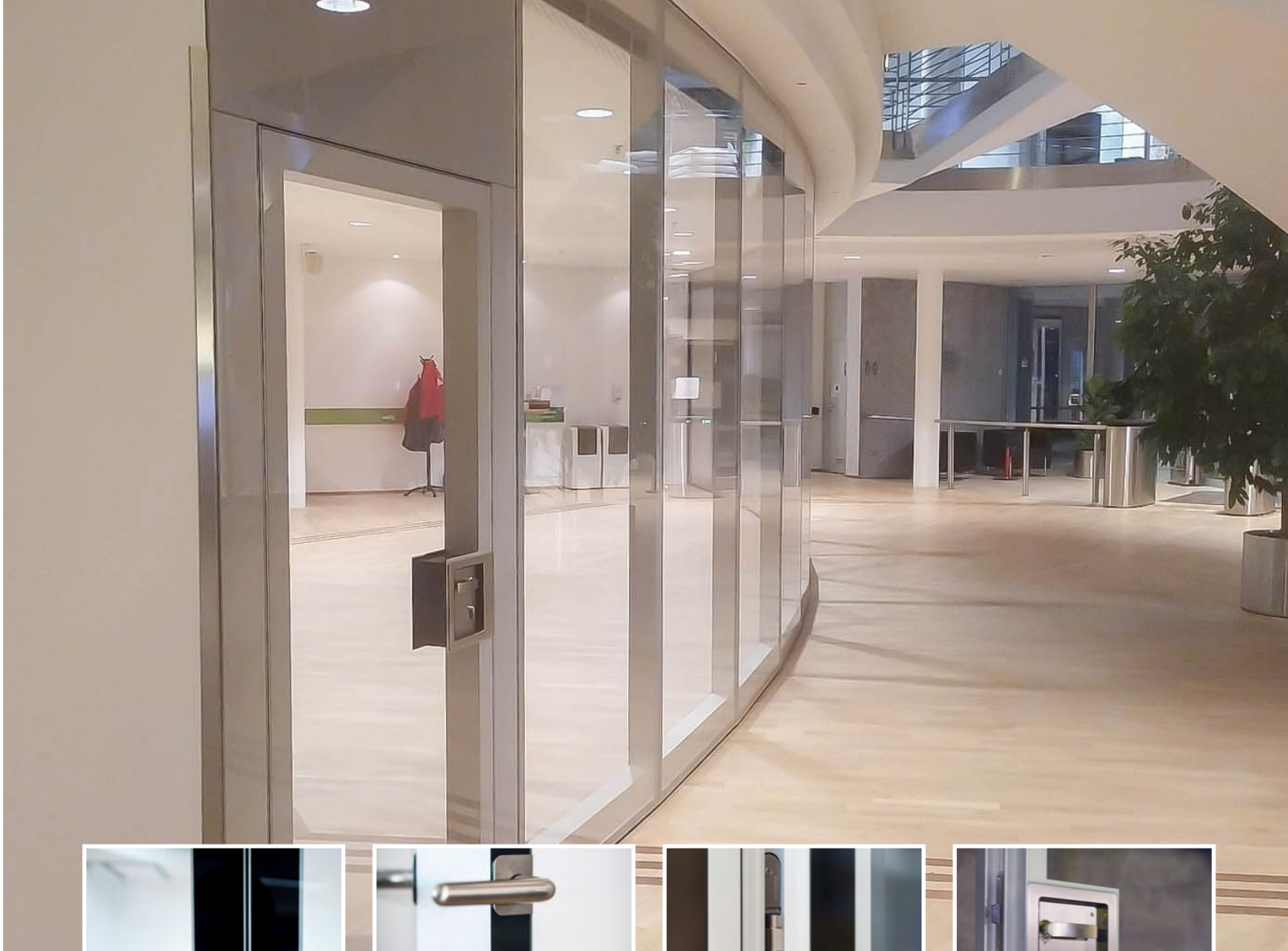

NIMBUS

DESIGNED FOR MOVEMENT
AND FLOW.

Spaces perform best when they balance connection and privacy. Office environments demand light, transparency, and adaptability all in the same workspace. NIMBUS double glazed walls maintain visual openness while delivering acoustic control, allowing teams to collaborate without sacrificing focus.

NIMBUS & CUMULUS MIX

Fluid Design Meets Timeless Craft



With multiple suspension and stacking options, NIMBUS adapts to a wide range of layouts. Panels can also be combined with CUMULUS solid panels, enabling designers to blend glazed and solid segments within a single, cohesive configuration.



ADDED VALUE AT EVERY STEP

THE BENEFITS YOU'LL NOTICE

BENEFITS

- Maintains visual transparency while creating flexible layouts.
- Enhances natural light across spaces.
- Allows environments to transition easily between collaborative and private settings.
- Supports modern architectural aesthetics.





ADDED VALUE AT EVERY STEP

ENHANCED FEATURES. BETTER RESULTS.

ADDED FEATURES

- Sound Transmission Class (STC) rating of 44-49.
- Integrated door options available.
- Fire-rated system certification.
- Customizable metal finishes and coatings.
- Multiple configuration options.
- Stackable up to 4.5 meters (14'-76') in height.
- Available in Frosted or Switchable Glass.
- Compatible with CUMULUS for mixed glazed and solid wall designs.
- Once programmed, each panel moves to its pre-set location.
- In a power outage the partition can still be operated using the back-up battery.
- NIMBUS is available in Manual, Hybrid or Smart deployment options.

FINISHES COLLECTION

TIMELESS ELEGANCE, ENDLESS OPTIONS



Glass



6MM GLASS



RAL 9010
Pure White



RAL 9005
Black

Powder Coating



RAL 9005
Jet Black
(textured)

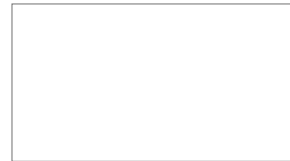

RAL 9010
Pure White
(textured)

Custom RAL



Custom RAL

Note: Other profiles and custom finishes upon request.

STACKING SYSTEMS

NIMBUS supports configurations for parking panels when open, enabling flexible space division in architectural settings.



CENTRE STACKING SYSTEM

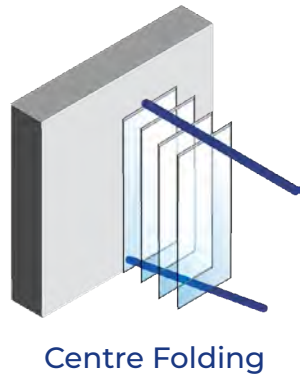

MAIN STACKING SYSTEM

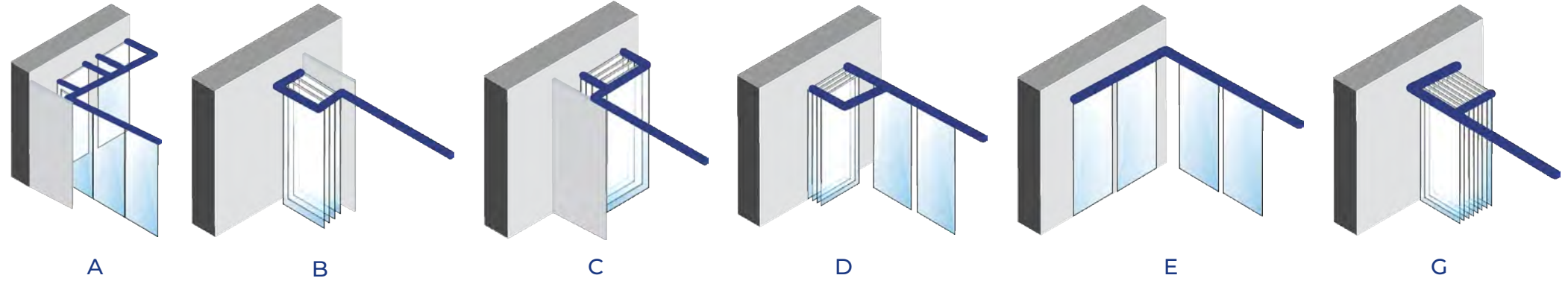



HEAD OFFICE
130 Nolan Court
Markham, ON L3R 2V7
Canada

T. 1-866-633-0233
E. hello@pc350.com
www.pc350.com

USA
T. 1-866-633-0233
E. hello@pc350.com

CARIBBEAN
T. 1-866-633-0233
E. hello@pc350.com

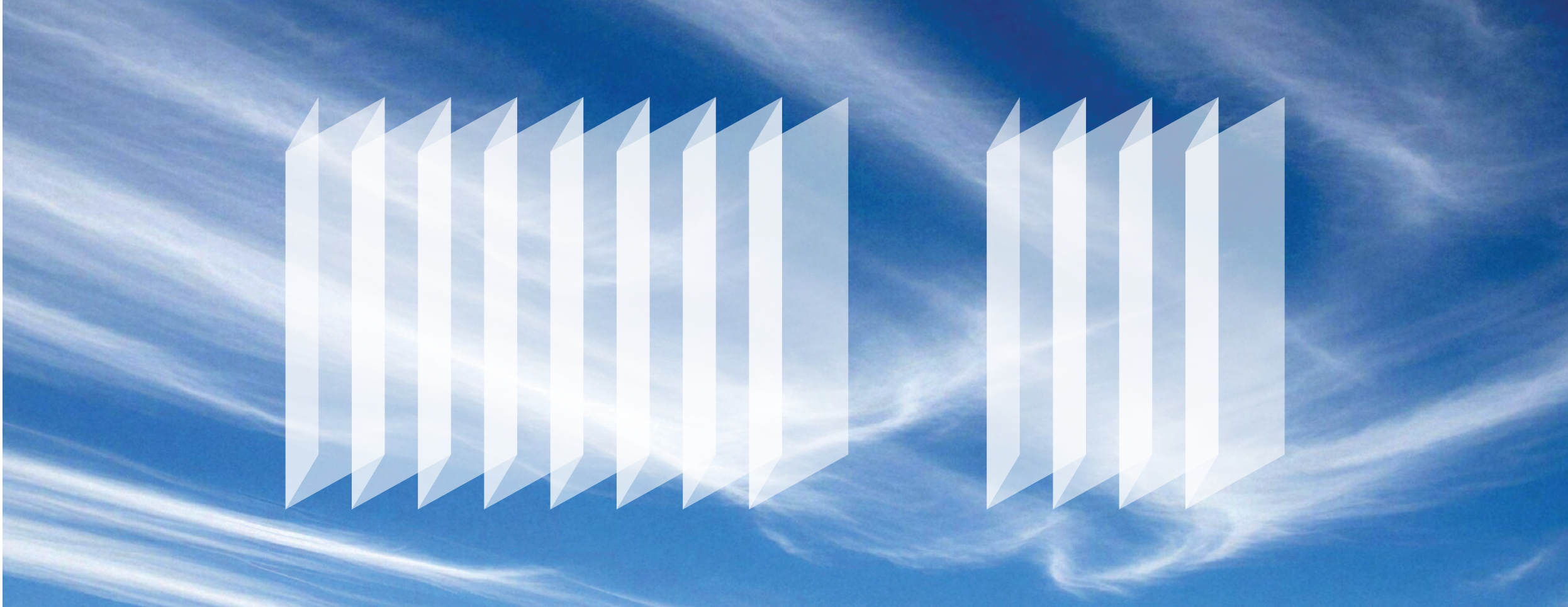

SOUND
INSULATION



SMART



SEVERAL
FINISHES



GLASS

CIRRUS



CIRRUS

DESIGNED FOR MOVEMENT
AND FLOW.

CIRRUS introduces flexible configurations with sliding and folding panels that allow rooms to evolve throughout the day. From open environments to segmented spaces, CIRRUS is the solution for dynamic environments that require spaces that can adapt without disruption.

ADDED VALUE AT EVERY STEP

THE BENEFITS YOU'LL NOTICE

BENEFITS

- Allows spaces to expand or divide depending on use.
- Maximizes room functionality throughout the day.
- Supports flexible layouts for events, meetings, or multi-purpose environments.
- Enhances space efficiency without permanent partitions.
- Available in floor-supported or top-hung configurations.



ADDED VALUE AT EVERY STEP

ENHANCED FEATURES. BETTER RESULTS.

ADDED FEATURES

- Sound Transmission Class (STC) rating of 42-43 STC.
- Certified fire safety standards.
- Multiple finish and coating possibilities.
- Configurations available in manual or assisted operation.
- Double glazed.
- Available in Frosted or Switchable Glass.
- Solid Panel Options.
- CIRRUS is available in Manual or Smart Deployment options.



FINISHES COLLECTION

TIMELESS ELEGANCE, ENDLESS OPTIONS



C I R R U S

MFC



Laminate



Fabric



HPL



Writable

Custom RAL



Custom RAL

Note: Other profiles and custom finishes upon request.

STACKING SYSTEMS

CIRRUS supports configurations for parking panels when open, enabling flexible space division in architectural settings.

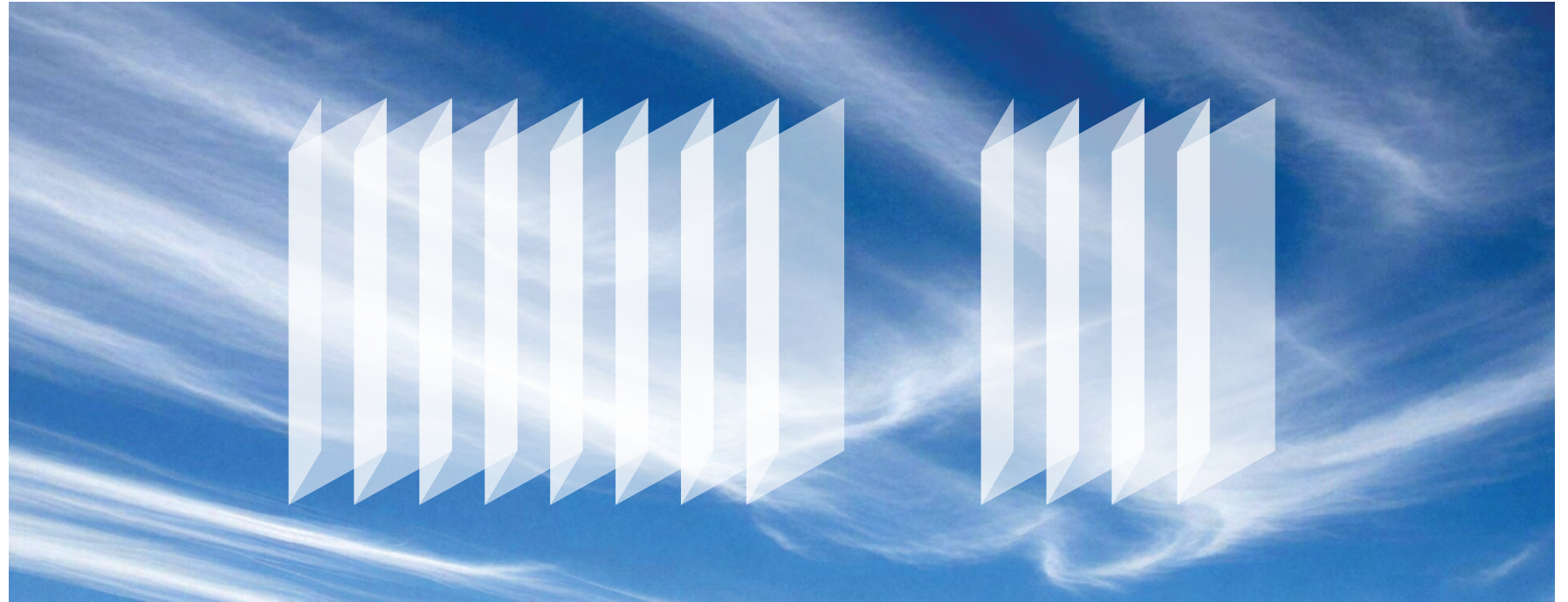

FLOOR GUIDED

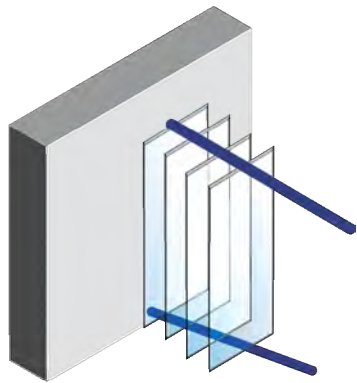

Centre Folding

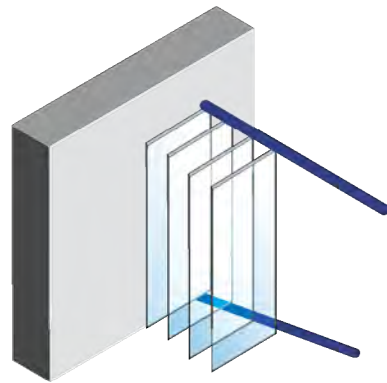

Side Stacking

MODULAR WALL

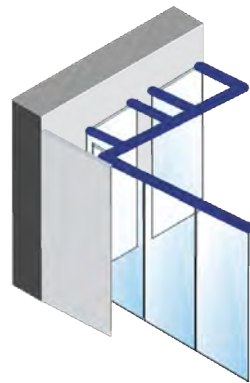

A

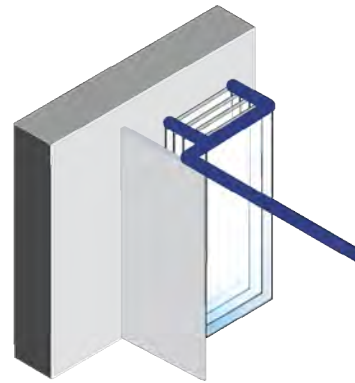

C

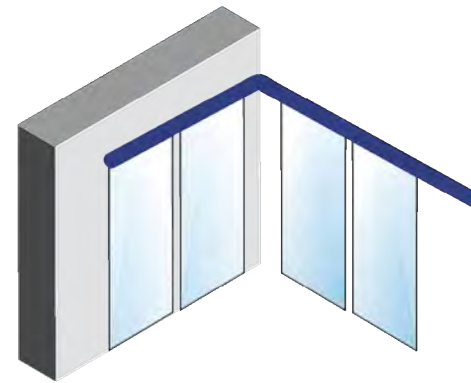

E

TOP HUNG

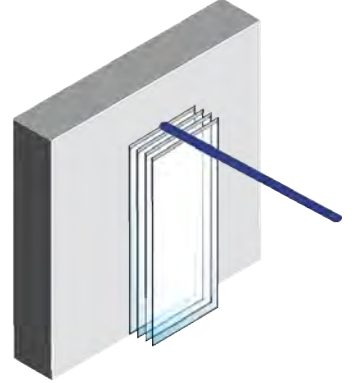

F



HEAD OFFICE
130 Nolan Court
Markham, ON L3R 2V7
Canada

T. 1-866-633-0233
E. hello@pc350.com
www.pc350.com

USA
T. 1-866-633-0233
E. hello@pc350.com

CARIBBEAN
T. 1-866-633-0233
E. hello@pc350.com

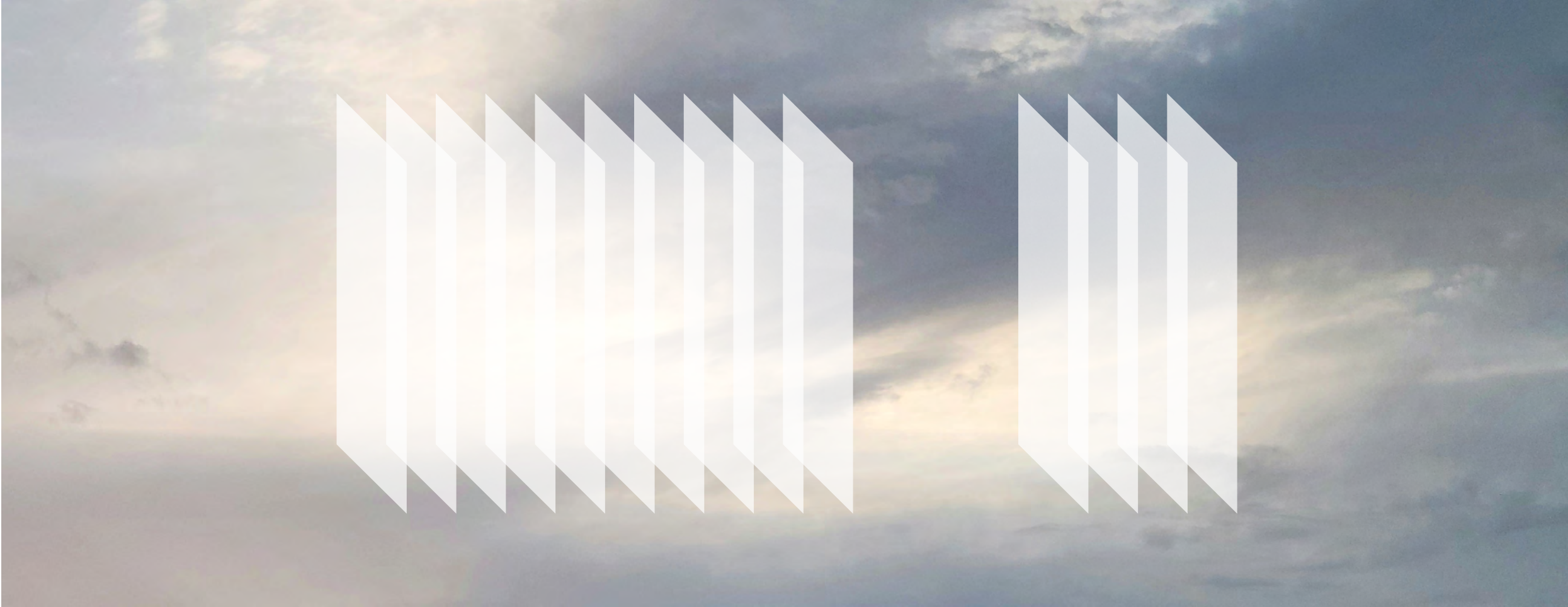

SOUND
INSULATION



MANUAL

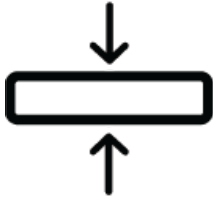

THIN



GLASS

ALTO



ALTO

OPEN DESIGN,
UNINTERRUPTED VIEWS.

Great architecture connects spaces while allowing them to evolve. ALTO walls combine minimal structure with flexible configurations, creating adaptable layouts. The best designed spaces are the ones that adapt without compromising design.

ALTO, flexibility meets transparency.

ADDED VALUE AT EVERY STEP

THE BENEFITS YOU'LL NOTICE

BENEFITS

- Maintains openness while allowing space division.
- Enhances natural light and visual connectivity.
- Supports flexible environments without heavy structural elements.
- Ideal for modern, design-driven interiors.



ADDED VALUE AT EVERY STEP

ENHANCED FEATURES. BETTER RESULTS.

ADDED FEATURES

- Minimal glass panel system for clean architectural lines.
- Sliding and pivoting panel configurations.
- Sound Transmission Class (STC) rating of up to 35.
- Certified fire resistance options available.
- Wide range of customizable finishes.
- Available in Frosted Glass.
- Sliding, Swing and Pocket Door options.
- Manual Deployment only available.



FINISHES COLLECTION

TIMELESS ELEGANCE, ENDLESS OPTIONS



Powder Coating



RAL 9005
JET BLACK
(textured)

Glass

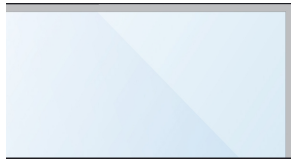

8MM GLASS

Sublimation



H3331 ST10 Natural
Nebraska Oak



3734 ST9 Natural
Dijon Walnut

Custom RAL



Custom RAL

Note: Other profiles and custom finishes upon request.

STACKING SYSTEMS

ALTO supports configurations for parking panels when open, enabling flexible space division in architectural settings.

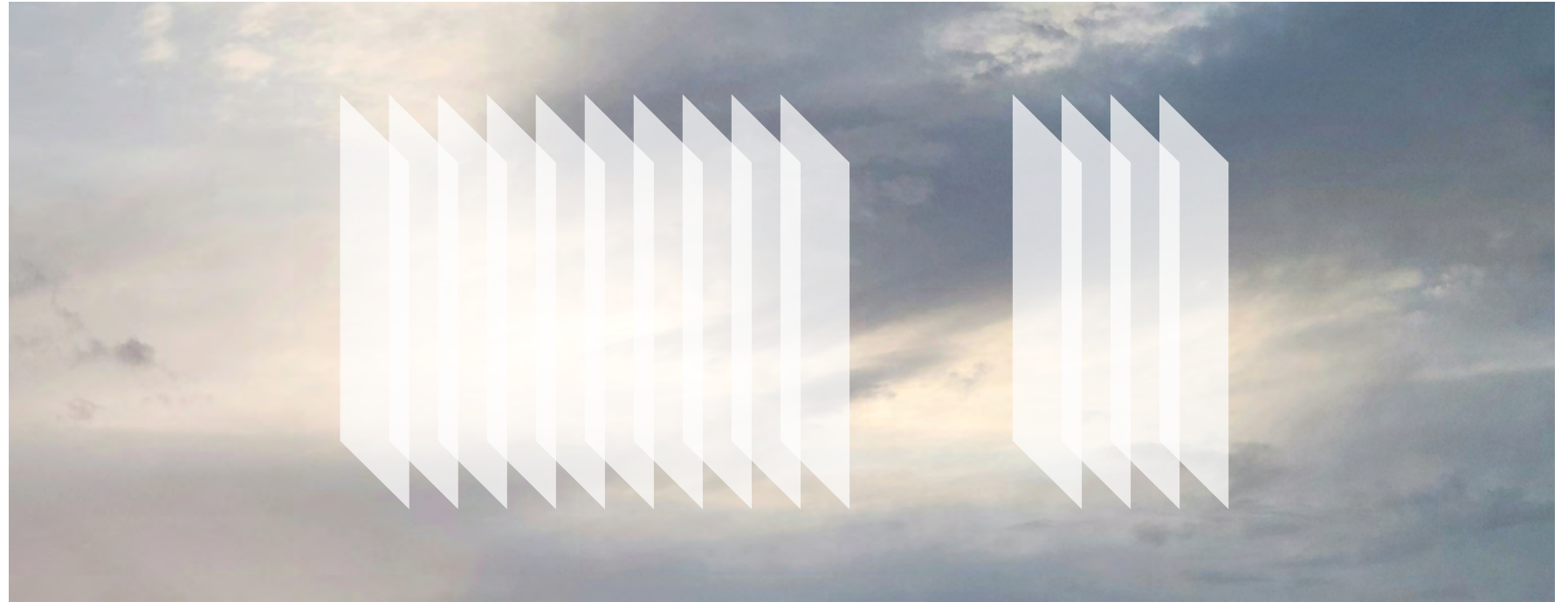

FLOOR GUIDED

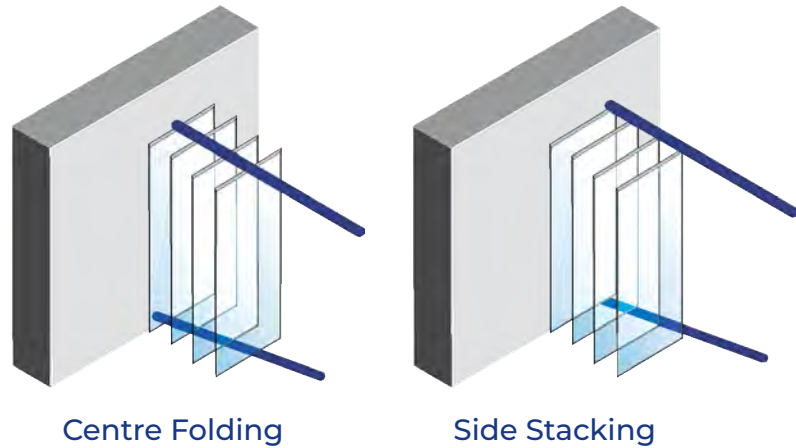

Centre Folding

Side Stacking

MODULAR WALL

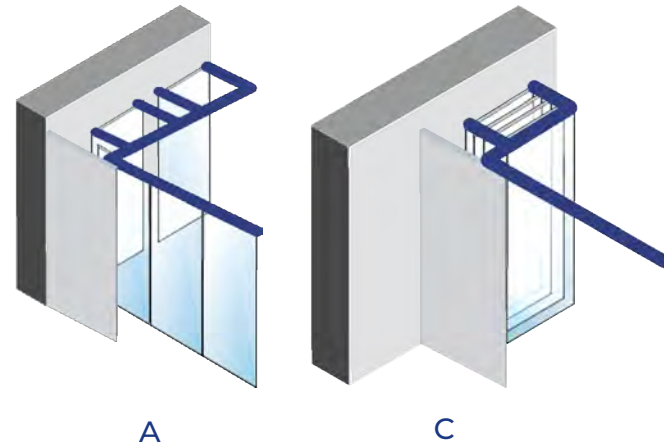

A

C

SLIDING DOOR

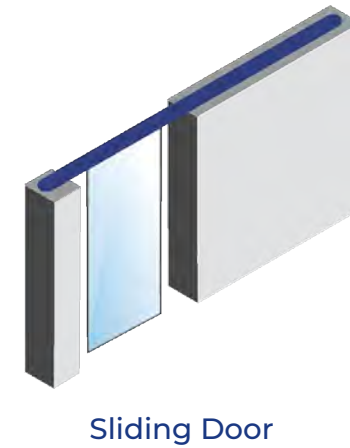

Sliding Door

PIVOTING WALL

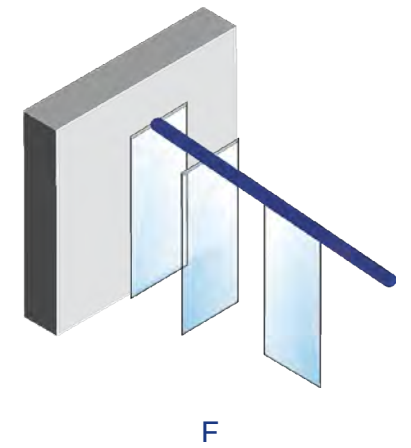

F



HEAD OFFICE
130 Nolan Court
Markham, ON L3R 2V7
Canada

T. 1-866-633-0233
E. hello@pc350.com
www.pc350.com

USA
T. 1-866-633-0233
E. hello@pc350.com

CARIBBEAN
T. 1-866-633-0233
E. hello@pc350.com